

Write your name here

Surname

Other names

Centre Number

Candidate Number

**Edexcel IGCSE**

**Mathematics A**

**Paper 2F**



**Foundation Tier**

Friday 10 June 2011 – Morning

**Time: 2 hours**

Paper Reference

**4MA0/2F**

**You must have:**

Ruler graduated in centimetres and millimetres, protractor, compasses, pen, HB pencil, eraser, calculator. Tracing paper may be used.

Total Marks

### Instructions

- Use **black** ink or ball-point pen.
- **Fill in the boxes** at the top of this page with your name, centre number and candidate number.
- Answer **all** questions.
- Without sufficient working, correct answers may be awarded no marks.
- Answer the questions in the spaces provided  
– *there may be more space than you need.*
- **Calculators may be used.**
- You must **NOT** write anything on the formulae page.  
Anything you write on the formulae page will gain NO credit.

### Information

- The total mark for this paper is 100.
- The marks for **each** question are shown in brackets  
– *use this as a guide as to how much time to spend on each question.*

### Advice

- Read each question carefully before you start to answer it.
- Check your answers if you have time at the end.

Turn over ►

P38580A

©2011 Edexcel Limited.

6/6/6/6



**edexcel**   
advancing learning, changing lives

# IGCSE MATHEMATICS

## FORMULA SHEET – FOUNDATION TIER

Pythagoras' Theorem  
 $a^2 + b^2 = c^2$

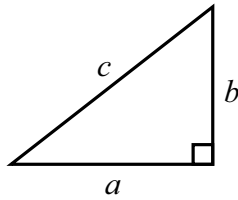

Area of a trapezium =  $\frac{1}{2}(a + b)h$

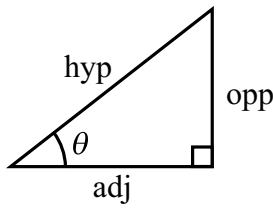
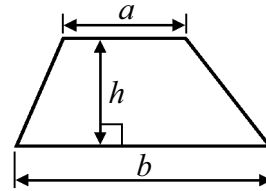

adj = hyp  $\times$  cos  $\theta$   
 opp = hyp  $\times$  sin  $\theta$   
 opp = adj  $\times$  tan  $\theta$

Volume of prism = area of cross section  $\times$  length

or  $\sin \theta = \frac{\text{opp}}{\text{hyp}}$

$\cos \theta = \frac{\text{adj}}{\text{hyp}}$

$\tan \theta = \frac{\text{opp}}{\text{adj}}$

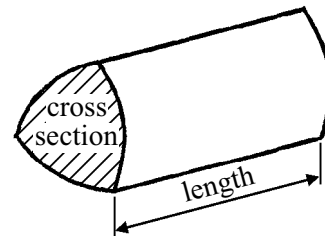

Circumference of circle =  $2\pi r$

Area of circle =  $\pi r^2$

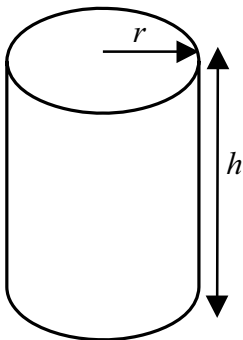

Volume of cylinder =  $\pi r^2 h$

Curved surface area of cylinder =  $2\pi r h$

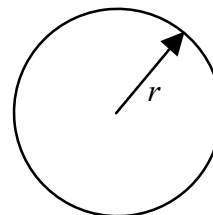

Answer ALL TWENTY SIX questions.

Write your answers in the spaces provided.

You must write down all the stages in your working.

1

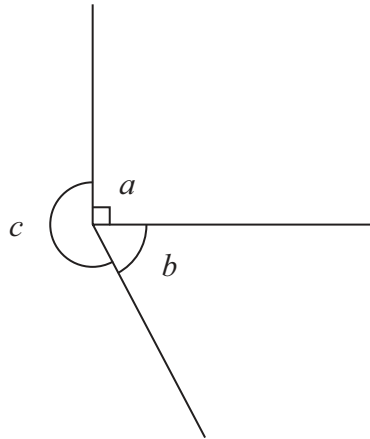

The diagram shows three angles labelled  $a$ ,  $b$ , and  $c$ .

Write down the mathematical name for each of the three angles.

(i)  $a$  .....

(ii)  $b$  .....

(iii)  $c$  .....

(Total for Question 1 is 3 marks)

Do NOT write in this space

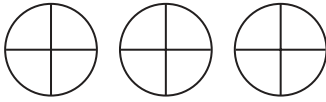
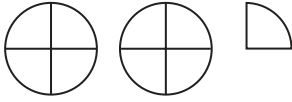
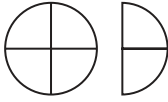

- 2 The pictogram shows information about the number of goals scored by Newton United in 3 months of a football season.

|           |   |
|-----------|---|
| August    |  |
| September |  |
| October   |  |
| November  |   |

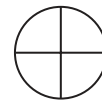

represents 4 goals

- (a) How many goals did Newton United score in August?

.....  
(1)

- (b) How many more goals did Newton United score in September than in October?

.....  
(2)

In November, Newton United scored 10 goals.

- (c) Show this information on the pictogram.

(1)

Newton United scored 20% of their 10 goals in November from headers.

- (d) Work out 20% of 10

.....  
(2)

**(Total for Question 2 is 6 marks)**



3 (a) Write down the value marked with the arrow.

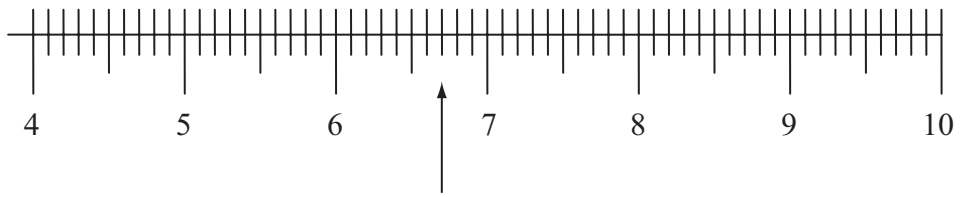

.....  
(1)

(b) (i) Mark with an arrow the number 3.64

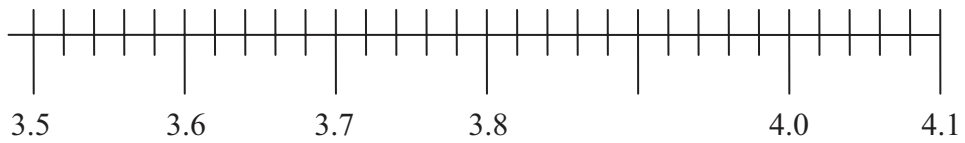

(1)

(ii) Write down the value of the number exactly half way between 3.8 and 4.0

.....  
(1)

(iii) Write 3.64 to the nearest whole number.

.....  
(1)

**(Total for Question 3 is 4 marks)**

**Do NOT write in this space**



4

8

10

11

15

16

20

21

(a) From the numbers in the box, write down

(i) the square number,

.....

(ii) the factor of 70,

.....

(iii) the number which is a multiple of both 3 and 5,

.....

(iv) the prime number,

.....

(v) the cube number.

.....

(5)

(b) Write down two numbers from the box which have a difference of 9

....., .....

(1)

(c) Use a number from the box to make the following statement true.

$$8 - \dots = -7$$

(1)

**(Total for Question 4 is 7 marks)**

**Do NOT write in this space**



5 The diagram shows a parallelogram  $PQRS$  drawn on a centimetre grid.

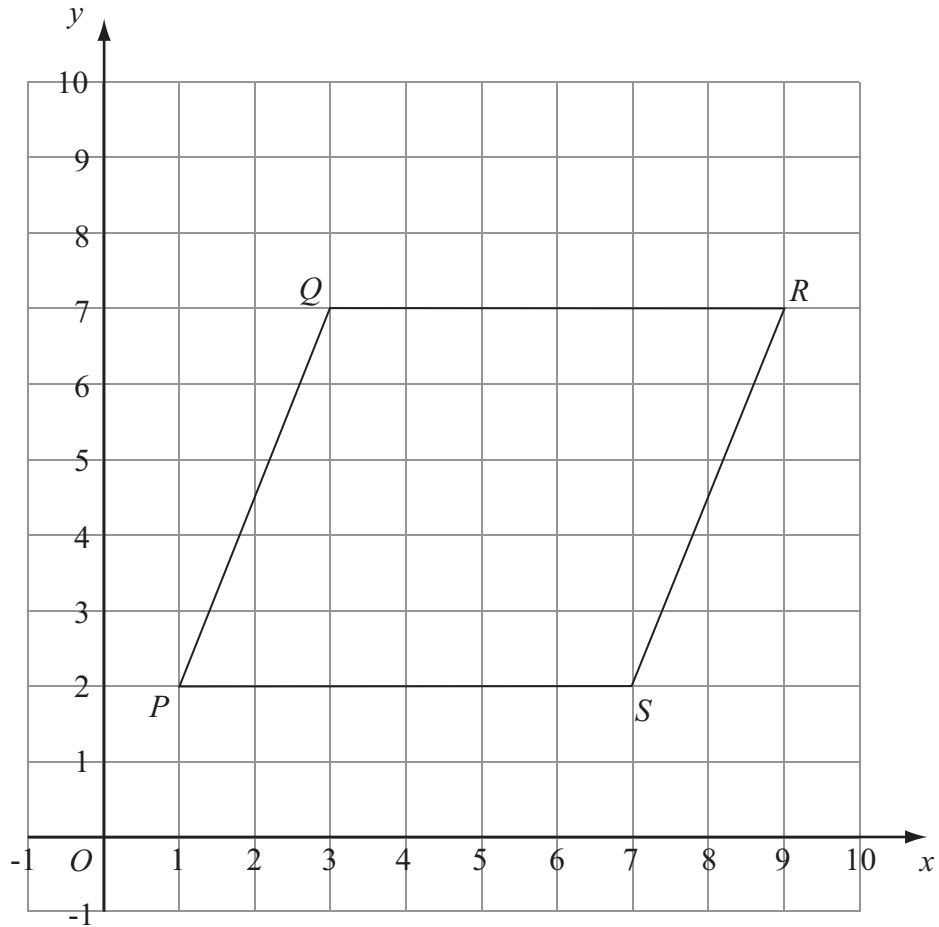

(a) Measure the length of  $PQ$ .

..... cm  
(1)

(b) Write down the coordinates of the point  $R$ .

(....., .....)  
(1)

(c) Work out the area of the parallelogram  $PQRS$ .  
Give the units of your area.

.....  
(3)

(Total for Question 5 is 5 marks)



6 Here are five road signs.

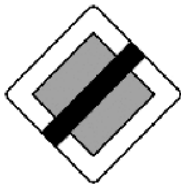

A



B



C

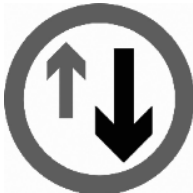

D



E

**Two** of these five road signs have only one line of symmetry.

(a) Write down the letters of each of these two road signs.

..... and ..... (1)

Only **one** of these five road signs has rotational symmetry.

(b) (i) Write down the letter of this road sign.

.....

(ii) Write down the order of rotational symmetry of this road sign.

.....

**(Total for Question 6 is 3 marks)**

7 (a) Write these decimal numbers in order of size.

Start with the smallest.

6.4

4.7

6.04

4.62

6.34

..... (1)

(b) Write  $6\frac{3}{4}$  as a decimal number.

..... (1)

**(Total for Question 7 is 2 marks)**





- 8 Pierre wants to convert some money between two currencies.  
This graph can be used to convert between Euros (€) and Canadian dollars (C\$).

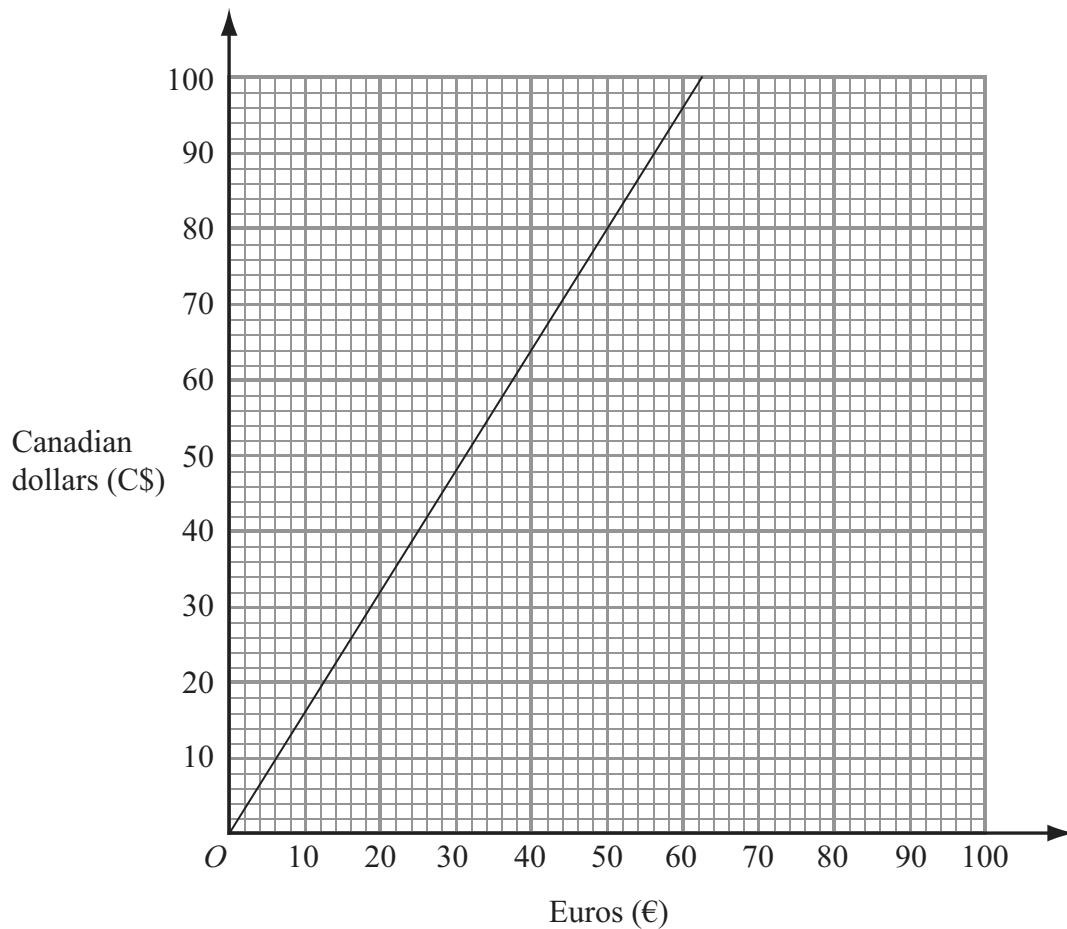

(a) Use the graph to convert

- (i) 50 Euros (€) to Canadian dollars (C\$),

C\$.....

- (ii) 60 Canadian dollars (C\$) to Euros (€).

€.....

(2)

Pierre now decides to use this rule to convert Euros to Canadian dollars.

Multiply the number of Euros by 8 and divide the result by 5

(b) Use this rule to convert 175 Euros to Canadian dollars.

C\$.....

(2)

(Total for Question 8 is 4 marks)



9 The table shows the temperatures, at midnight and the following noon, in 5 cities.

| City     | Midnight temperature (°C) | Noon temperature (°C) |
|----------|---------------------------|-----------------------|
| Paris    | -4                        | 4                     |
| Munich   | -3                        | 4                     |
| Brussels | -5                        | -1                    |
| Oslo     | -8                        | -2                    |
| Madrid   | 1                         | 12                    |

(a) Which city had the lowest midnight temperature?

.....  
(1)

(b) Work out by how many degrees the temperature rose between midnight and noon in Oslo.

..... °C  
(2)

**(Total for Question 9 is 3 marks)**

10 In a survey of 120 cars,  $\frac{3}{8}$  of the cars were red.

Work out  $\frac{3}{8}$  of 120

.....  
**(Total for Question 10 is 2 marks)**



- 11 Some people took a driving test.  
The pie chart shows information about their results.  
The pie chart is accurately drawn.

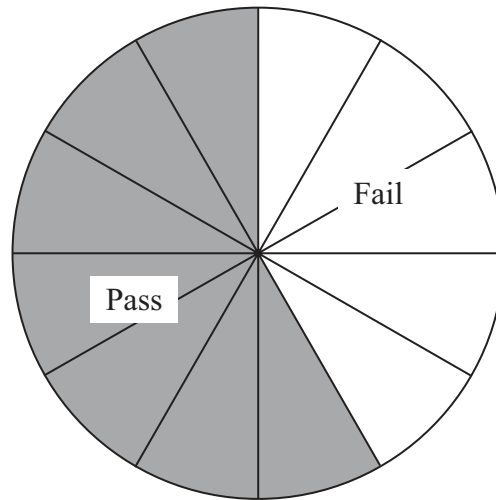

20 drivers failed the test.  
How many drivers passed the test?

.....  
(Total for Question 11 is 2 marks)

**Do NOT write in this space**



12 (a) Solve

(i)  $\frac{x}{4} = 7$

$x = \dots\dots\dots$

(ii)  $6y + 5 = 23$

$y = \dots\dots\dots$

(3)

(b) Simplify

(i)  $a \times a \times a \times a$ ,

$\dots\dots\dots$

(ii)  $5a \times 6b$ ,

$\dots\dots\dots$

(iii)  $q^8 \div q^2$ .

$\dots\dots\dots$

(3)

(c)  $v = w^2 - 2w$ .

Work out the value of  $v$  when  $w = 6$

$v = \dots\dots\dots$

(2)

(Total for Question 12 is 8 marks)



13 (a) Rachael uses her car for work.

Her company pays her 32 cents for every kilometre she travels by car.  
Yesterday, her company paid her \$48 for the distance she travelled by car.

Work out the distance she travelled by car yesterday.

..... km  
(3)

(b) The length of the journey from her home to work is 72 km.  
The journey takes 1 hour 20 minutes.

Work out her average speed in km/h.

..... km/h  
(3)

**(Total for Question 13 is 6 marks)**

**Do NOT write in this space**



- 14 Use compasses and a ruler only to construct the perpendicular bisector of the line  $PQ$ .  
You must show all construction lines.

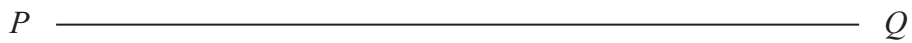

(Total for Question 14 is 2 marks)



15 Here is a list of ingredients for making Apple and Raspberry Crumble for 6 people.

**Apple and Raspberry Crumble**

Ingredients for 6 people

|           |                  |
|-----------|------------------|
| 120 grams | plain flour      |
| 230 grams | apples           |
| 200 grams | raspberries      |
| 160 grams | soft brown sugar |
| 90 grams  | butter           |

- (a) Sam wants to make Apple and Raspberry Crumble for 15 people.  
She has enough plain flour, soft brown sugar and butter.

Work out the amount of apples and the amount of raspberries Sam needs.

apples ..... grams

raspberries ..... grams

(3)

- (b) Find the fraction of the total weight of ingredients for 6 people that is soft brown sugar.

Give your answer in its simplest form.

.....  
(3)

**(Total for Question 15 is 6 marks)**



16 Here is a map of an island.

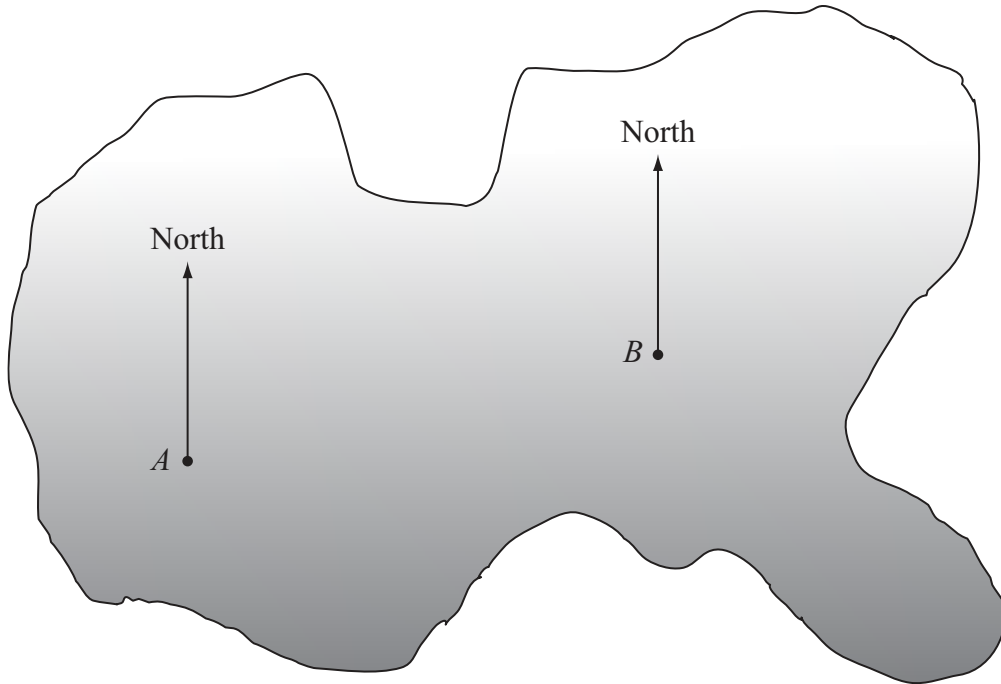

*A* and *B* are points on the island.

The scale of the map is 1 cm to 5 km.

(a) Find the real distance, in kilometres, between *A* and *B*.

..... km

(2)

(b) By measuring, find the bearing of *B* from *A*.

..... °

(1)

(c) Find the bearing of *A* from *B*.

..... °

(1)

Treasure is buried at a point **on** the island.

This point is 30 km from *A* and on a bearing of  $320^\circ$  from *B*.

(d) Find the point on the map where the treasure is buried.

Mark this point with an *X*.

(2)

**(Total for Question 16 is 6 marks)**





17 Here are two bags A and B.  
 Each bag contains 3 discs.  
 Each disc has a number on it.

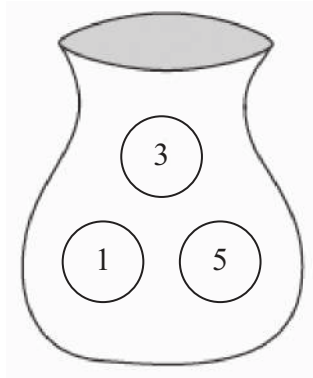

Bag A

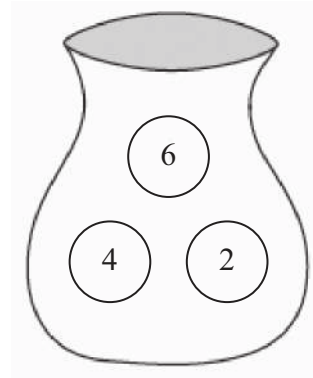

Bag B

Anton takes, at random, a disc from bag A and a disc from bag B.  
 His score is the sum of the numbers on these two discs.

(a) Complete the table to show all his possible scores.

(2)

|       |   | Bag A |   |   |
|-------|---|-------|---|---|
|       |   | 1     | 3 | 5 |
| Bag B | 2 |       | 5 |   |
|       | 4 |       |   |   |
|       | 6 |       |   |   |
|       |   |       |   |   |

(b) Find the probability that his score is 7

(2)

(Total for Question 17 is 4 marks)



18 On the grid, draw the graph of  $y = 2x - 1$

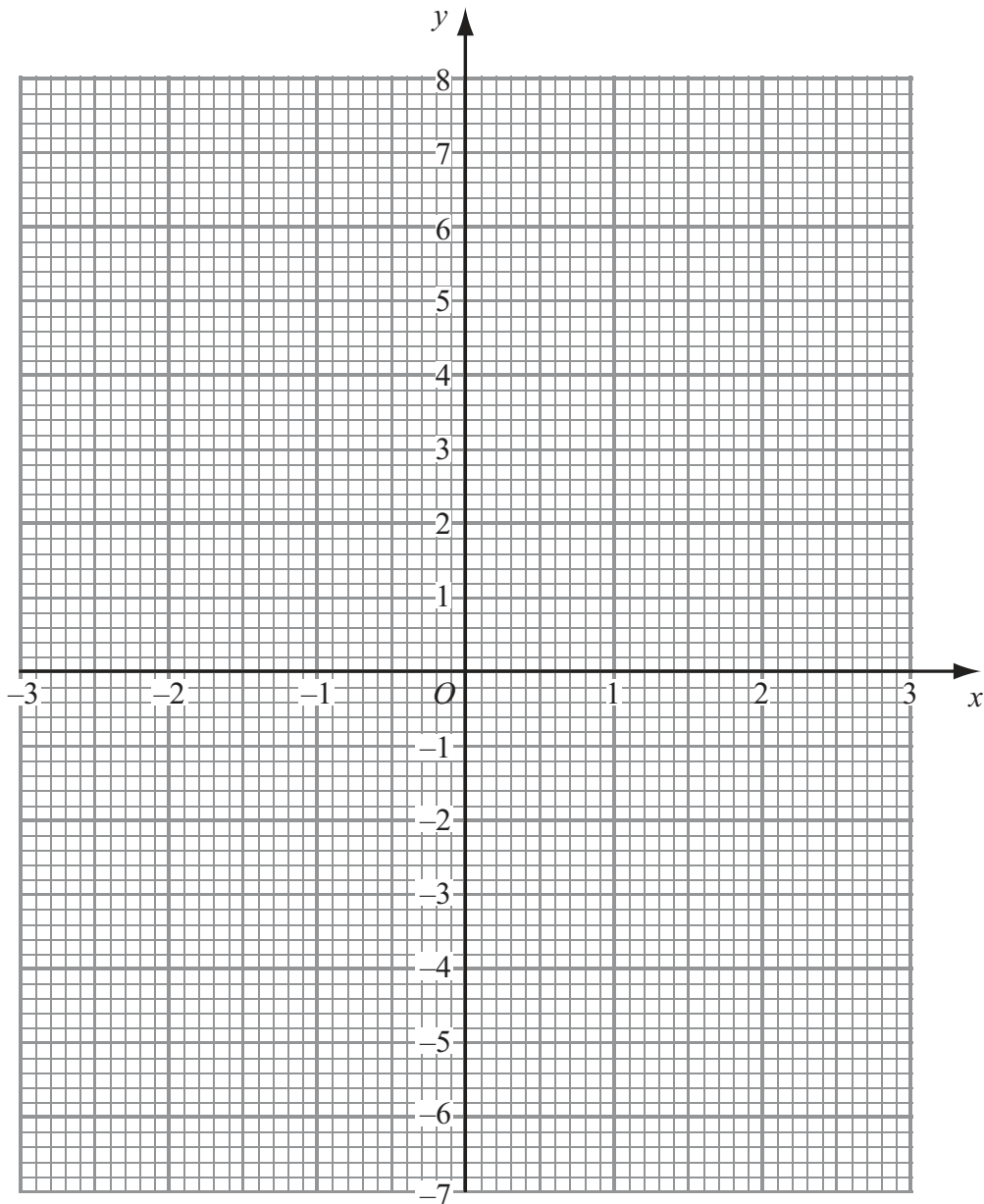

(Total for Question 18 is 4 marks)



19 In a sale, normal prices are reduced by 15%.  
The normal price of a television was \$640

Work out the sale price of the television.

\$ .....

**(Total for Question 19 is 3 marks)**

20 John throws a biased coin 120 times.  
It shows heads 90 times.

(a) John throws the coin once more.

Work out an estimate for the probability that the coin shows **tails**.

.....  
(2)

Carly throws the same coin 200 times.

(b) Work out an estimate for the number of times the coin shows **tails**.

.....  
(2)

**(Total for Question 20 is 4 marks)**



21

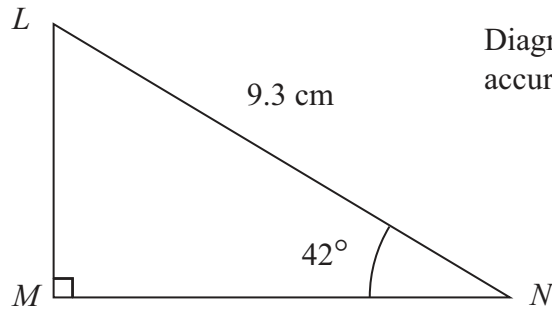

Diagram **NOT** accurately drawn

Calculate the length of  $LM$ .  
Give your answer correct to 3 significant figures.

..... cm

**(Total for Question 21 is 3 marks)**

22 Six numbers have a mean of 5

Five of the numbers are

3      2      7      6      2

The other number is  $x$ .

Work out the value of  $x$ .

$x =$  .....

**(Total for Question 22 is 3 marks)**



**23** The length of a fence is 137 metres, correct to the nearest metre.

Write down

(i) the lower bound for the length of the fence,

..... metres

(ii) the upper bound for the length of the fence.

..... metres

**(Total for Question 23 is 2 marks)**

**24** Express 126 as a product of its prime factors.

.....  
**(Total for Question 24 is 3 marks)**



25 Solve the inequality  $5x + 7 \geq 22$

.....  
**(Total for Question 25 is 2 marks)**

26 Solve the simultaneous equations

$$4x + 2y = 23$$

$$3x - 2y = 5$$

$$x = \text{.....}$$

$$y = \text{.....}$$

**(Total for Question 26 is 3 marks)**

---

**TOTAL FOR PAPER IS 100 MARKS**



**BLANK PAGE**



**BLANK PAGE**

